

Simple Logic-Level Translation Interfaces 1.8V Microcontrollers and 3V Peripherals

Interfacing a 1.8V microcontroller to a 3V peripheral poses a design challenge, because the logic output of the microcontroller cannot satisfy the peripheral's V_{IH} and V_{IL} requirements. A logic-level translator needs to be used to interface the two devices. The interface circuit can consist of a simple resistor and diode or an integrated logic-level translator.

Microcontrollers (μ Cs) powered from 1.8V cannot meet the V_{IH} requirements of peripheral devices that have typical CMOS inputs and are powered from 3V. General-purpose I/O pins on μ Cs are either open-drain structures that pull up to V_{DD} or down to near GND, or are push-pull outputs that pull up to nearly V_{DD} and down to nearly GND. These general-purpose I/Os need to be able to drive shutdown or interrupt pins of peripheral devices, even when the peripheral is powered from a supply higher than the μ C's power supply. The circuit shown in **Figure 1** solves this problem with a simple level translator circuit.

Typical peripheral CMOS I/O pins have a V_{IH} of $(0.7 \times V_{DD})$ and a V_{IL} of $(0.3 \times V_{DD})$. When powered from a 3V supply, these voltages are 2.1V and 900mV, respectively. Valid digital signals connected to these logic pins must drive higher than V_{IH} , and pull lower than V_{IL} , to ensure proper communication. The circuit in Figure 1 shows the MAX9718, a 1.4W audio power amplifier that employs a CMOS SHDN-bar input. The V_{IH} and V_{IL} levels of the SHDN-bar input are as described above.

The μ C I/O in Figure 1 is an open-drain I/O pulled up to 1.8V. When the open-drain output is low, the voltage at the MAX9718's SHDN-bar pin is equal to one diode-forward voltage above GND, about 0.7V, which is well below the V_{IL} of the MAX9718's SHDN-bar input. When the open-drain output goes high, the voltage at SHDN-bar rises to 2.5V and the MAX9718 is able to turn on.

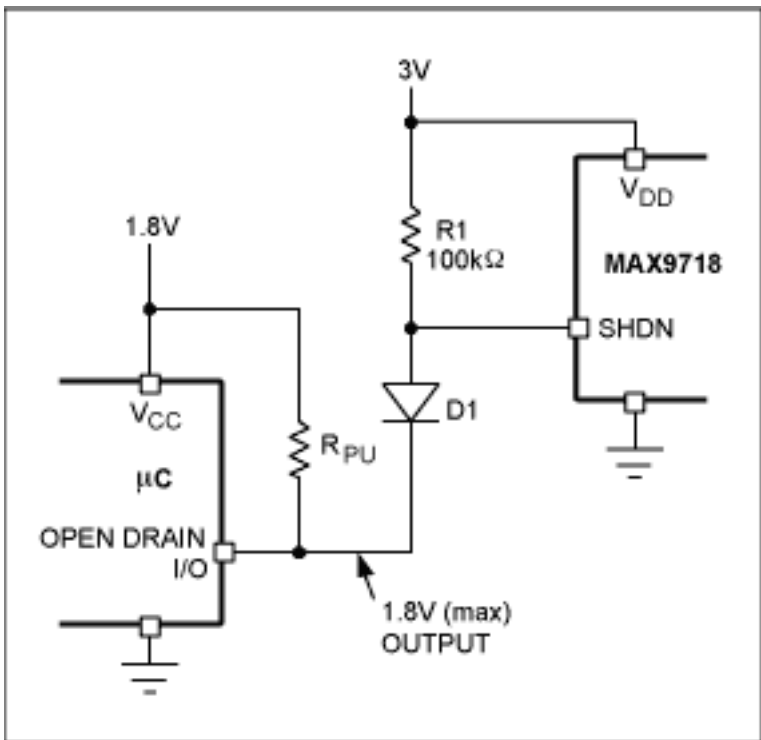

Figure 1. Simple Level Translator

Integrated level translators are available to simplify interconnect between two devices that do not share the same power supply. Devices such as the MAX13013 can translate a 1.2V digital signal to a 3.6V device at a speed of 100Mbps. **Figure 2** shows the proper connections for using the MAX13013 to interface a μC with the MAX9718.

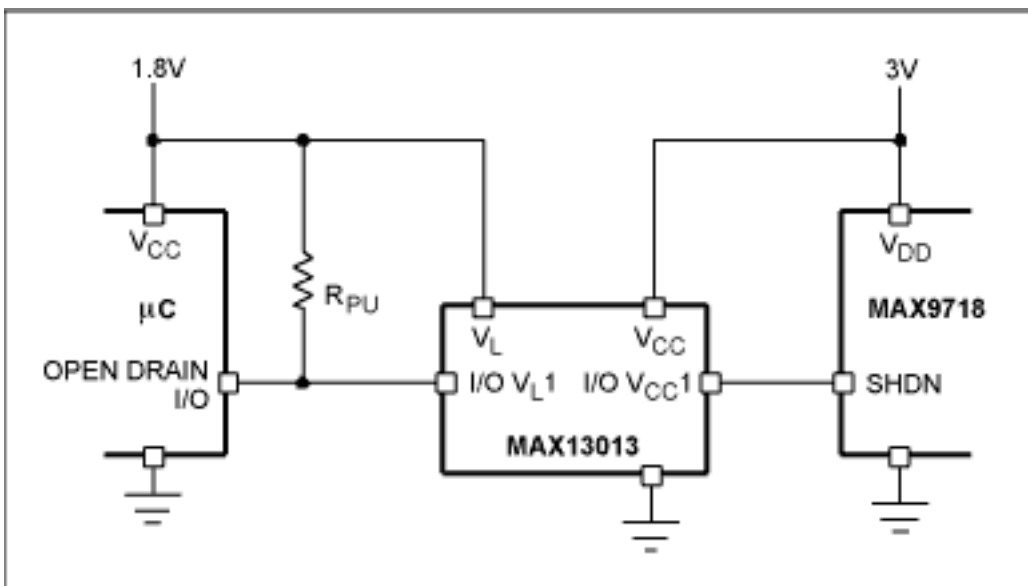

Figure 2. Using the MAX13013 to Interface a μC to the MAX9718

More Information

MAX13013: [QuickView](#) -- [Full \(PDF\) Data Sheet](#) -- [Free Samples](#)

MAX9718: [QuickView](#) -- [Full \(PDF\) Data Sheet](#) -- [Free Samples](#)